



## INTRODUCTION

StorWall is the smart alternative to joinery when it comes to integrated floor-to-ceiling filing and storage systems. It creates limitless fitout alternatives and provides the easiest way to tailor just the right combination of specialized types of storage to cater for individual needs. Matching low-height and specialist modules are also available.

## FEATURES

- StorWall's simple but elegant lines will compliment any office décor
- Internal fittings are interchangeable with other Dexion Office products
- The modular design of StorWall allows the system to be fully relocated or reconfigured
- Use free-standing, against walls, or to completely replace partition walls
- Dual-access and two-way corner units are available
- StorWall is adjustable at floor level
- All StorWall carcasses are constructed from robust powder-coated steel, with quality hinges, locks and runners throughout
- Low height and wall-mounted modules are available to provide fitout consistency
- Special features include desk, fridge and coat modules
- Scribe and blind panels provide an excellent finish

## TECHNICAL SPECIFICATIONS

**Accessory System** Ultima CI-80

### Standard Unit Heights

Low Heights	900 mm
	1050 mm
	1400 mm
Full Heights	2000 mm
	2400 mm
Custom Heights	2700 mm
	450 - 3000 mm

<b>Shelving Widths</b>	434 mm
	900 mm

<b>Bay Widths</b>	466 mm
	932 mm

<b>Shelving Depth</b>	400 mm
-----------------------	--------

<b>Bay Depth</b>	450 mm
------------------	--------

<b>Shelf Pitch</b>	25 mm
--------------------	-------

<b>Shelf Carrying Capacity</b>	Up to 130 kg
--------------------------------	--------------

<b>Bay Load Capacity</b>	Up to 450 kg
--------------------------	--------------

<b>Standard Finish*</b>	Stone White
-------------------------	-------------

<b>Timber Finish</b>	Various
----------------------	---------

\*Please refer to the Dexion Office Colour Selector for a selection of available powder coat colours.

## OVERALL DIMENSIONS

### Standard Units - Full Height

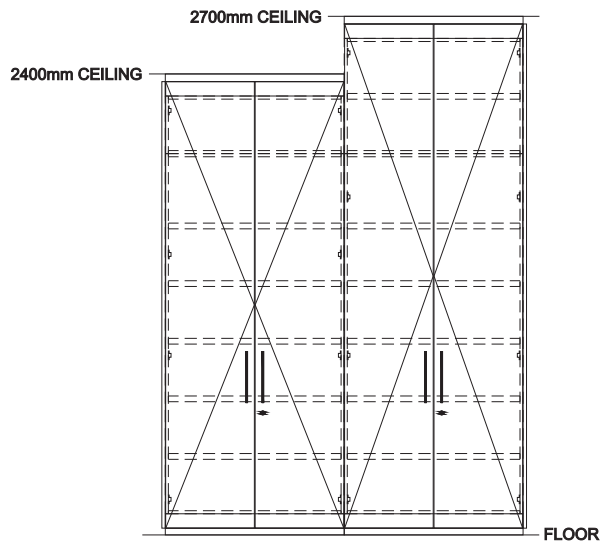

### Standard Units - Low Height

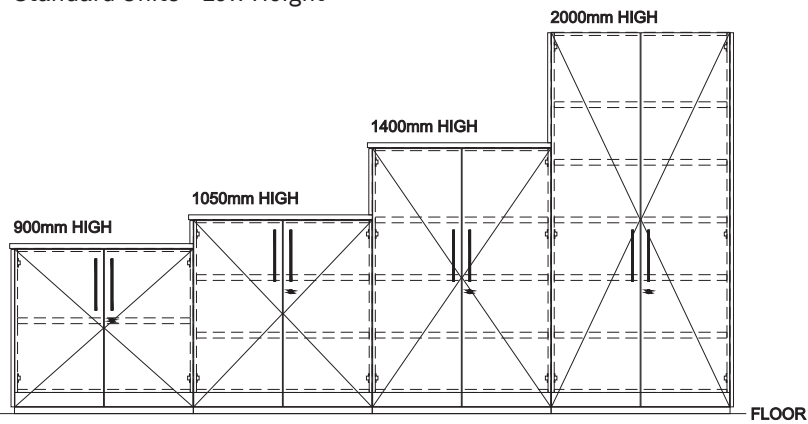

## ENQUIRIES

For contact details, visit  
[www.dexionoffice.com.au](http://www.dexionoffice.com.au)  
Or call 1300 180 358